

FRESA PER SPALLAMENTI RETTI

SHOULDER MILLING CUTTER

ECKFRÄSER 90 GRAD

T4490



**T4490 FRESA**  
**PER SPALLAMENTI RETTI**  
*Shoulder milling cutters*  
*Eckfräser 90 Grad*

**FRESE AD INSERTI**  
**INSERT MILLING CUTTERS**  
**WENDEPLATTEN-FRÄSWERKZEUGE**



# T4490

**FRESA PER SPALLAMENTI RETTI**  
*Shoulder milling cutter*  
*Eckfräser 90 Grad*

Per fresatura leggera  
 e media a spallamenti retti  
 di precisione

*Light and medium shoulder  
 milling cutter with true 90°*

*Für leichte-mittlere  
 Bearbeitungen  
 Eckfräsarbeiten mit  
 echtem 90-Grad-Schnitt*

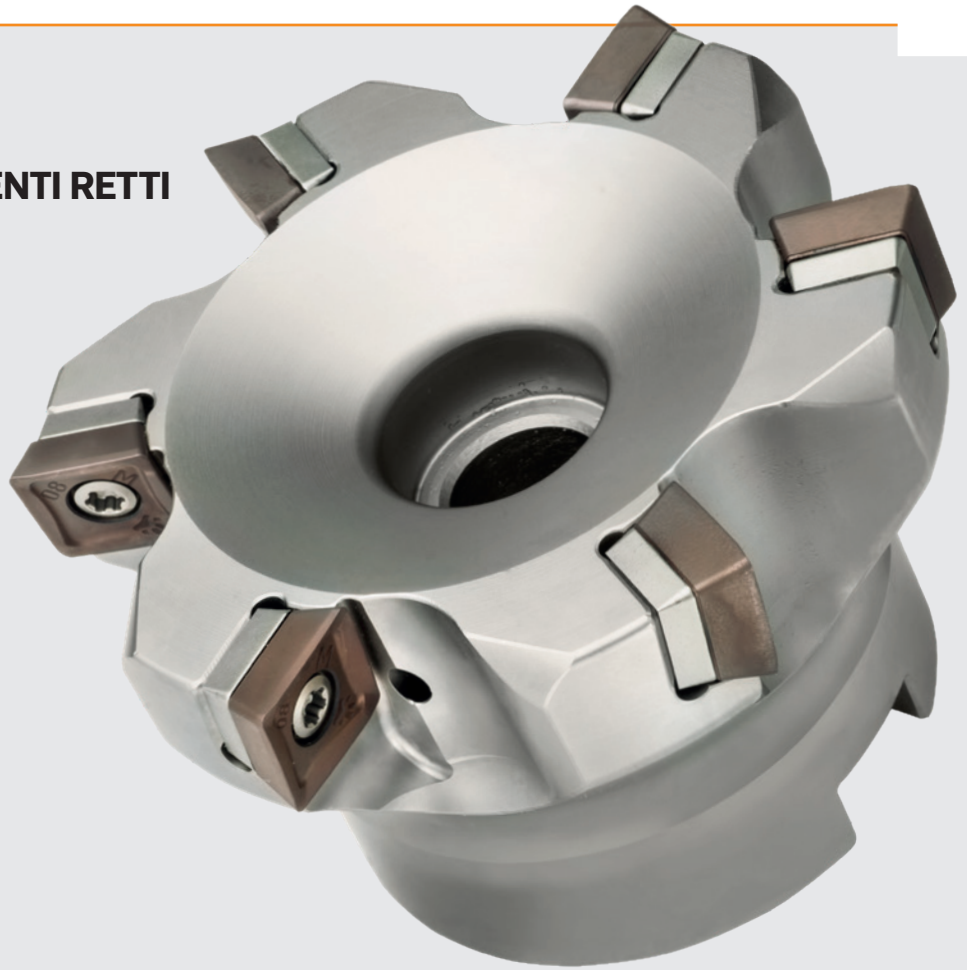

**Ø 20 ÷ 160**

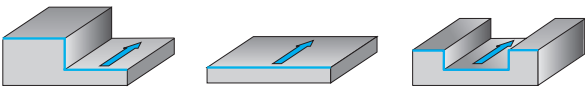

**DISPONIBILE  
 NEI PASSI:**

*Available in pitch:*

*Erhältlich mit der Steigung:*

**NORMALE**

*NORMAL*

*NORMAL*

**STRETTO**

*FINE*

*FEIN*



**Fori di  
 lubrorefrigerazione**

*Coolant holes  
 Kühlmittelbohrungen*



**High  
 Quality  
 STEEL**

**TAILOR  
 MADE**



**SO...09**

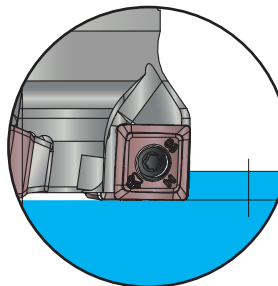

$A_p$  MAX 5 mm  
 $F_z$  MAX 0,3 mm

**SO...13**

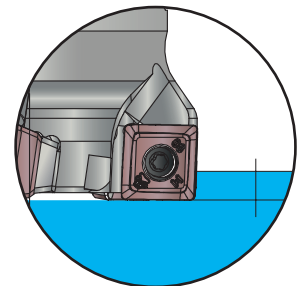

$A_p$  MAX 12 mm  
 $F_z$  MAX 0,5 mm

**T4490 FRESA**  
 PER SPALLAMENTI RETTI  
 Shoulder milling cutters  
 Eckfräser 90 Grad

**FRESE AD INSERTI**  
 INSERT MILLING CUTTERS  
 WENDEPLATTEN-FRÄSWERKZEUGE



## SOKX

**INSERTI AD ALTISSIME PRESTAZIONI**  
 High performance inserts  
 Hochleistungs-Wendeschneidplatten



### SOKX 0903... /SOEX 0903...

	R = 0,4	R = 0,8	R = 1,2
<b>F</b> finishing			
<b>M</b> medium			
<b>H</b> heavy			
<b>LL</b> Alluminium			

### Substrati e rivestimenti innovativi

New substrates and coatings

Innovative Substrate und Beschichtungen

**KH58**  
**KH108**  
**TC2600**

**KH78**

**KH118**  
**KH108**

**K15**

### SOKX 1304... /SOEX 1304...

	R = 0,8	R = 1,2	R = 1,6	R = 2,0
<b>F</b> finishing				
<b>M</b> medium				
<b>H</b> heavy				
<b>LL</b> Alluminium				

### XOKX



**RASCHIANTE**  
 Scraping  
 Breitschlichtplatte

**T4490 FRESA**  
**PER SPALLAMENTI RETTI**  
*Shoulder milling cutters*  
*Eckfräser 90 Grad*

**FRESE AD INSERTI**  
**INSERT MILLING CUTTERS**  
**WENDEPLATTEN-FRÄSWERKZEUGE**



## Inserto SO... 0903...

**Con fori di lubrorefrigerazione**

*With coolant holes*  
*mit Kühlmittelbohrungen*

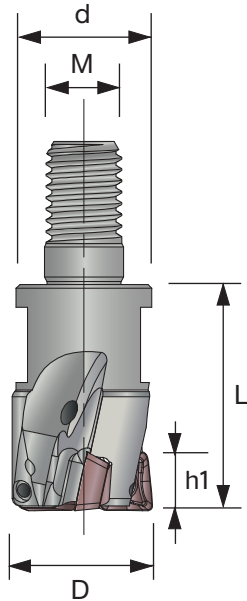

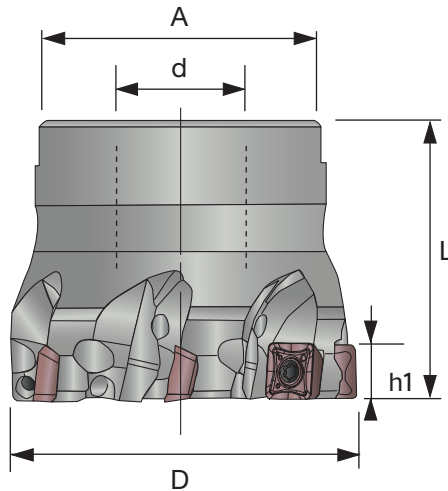

**TM**

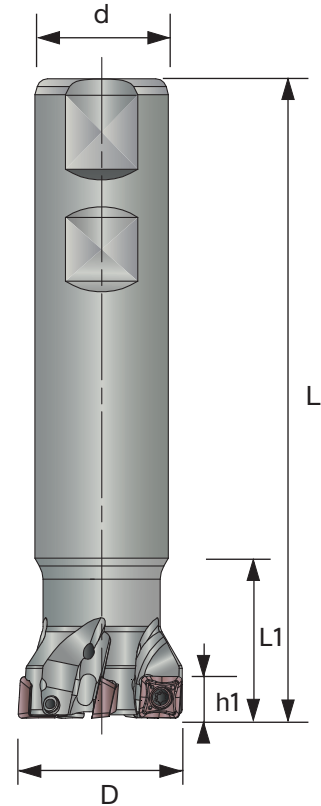

**PM**



**PW**

CODICE CODE	DIMENSIONI / DIMENSIONS / MAßE								INSERTO INSERT WSP		
	D	Z	d	L	L1	h1	A	M			
T4490TM 10 020.S009 Z3 W	20	3		30		9		10	<b>SOKX 0903...</b> <b>SOEX 0903...</b>	<b>VT4490.09</b>	<b>CVT08P</b>
T4490TM 12 025.S009 Z4 W	25	4		35		9		12			
T4490TM 16 032.S009 Z5 W	32	5		40		9		16			
T4490TM 16 040.S009 Z6 W	40	6		40		9		16			
T4490PM 040.S009 Z6 W	40	6	16	40		9	35				
T4490PM 050.S009 Z7 W	50	7	22	40		9	43				
T4490PW 020.S009 Z3 W	20	3	20	100	30	9					
T4490PW 025.S009 Z4 W	25	4	25	120	30	9					
T4490PW 032.S009 Z5 W	32	5	32	120	30	9					
T4490PW 032.S009 Z5 W G25	32	5	25	100	30	9					



**Per un corretto montaggio utilizzare il riferimento sull'inserto**

*Use the insert reference for a correct fitting up*

*Für die korrekte Montage der WSP achten Sie bitte auf die Bezugsmarkierung*



## Inserti per fresa T4490.S009

Inserts for T4490.S019 milling cutter / WSP für T4490.S009 Fräser



CODICE CODE	DIMENSIONI DIMENSIONS / MAßE			P	M	K	N
	L	S	R				
SOKX 090304 PZR-F	9,52	3,18	0,4	KH108 KH58	KH78	KH108	
SOKX 090308 PZR-F	9,52	3,18	0,8	KH108 KH58	KH78	KH108	
SOKX 090304 PZR-M	9,52	3,18	0,4	KH108 KH58	KH78	KH108	
SOKX 090308 PZR-M	9,52	3,18	0,8	KH108 KH58	KH78	KH108	
SOKX 090312 PZR-M	9,52	3,18	1,2	KH108 KH58	KH78	KH108	
SOKX 090308 PZR-H	9,52	3,18	0,8	KH108 KH58	KH78	KH108	
SOKX 090312 PZR-H	9,52	3,18	1,2	KH108 KH58	KH78	KH108	
SOEX 090304 PZR-LL	9,52	3,18	0,4				K15



## Parametri di taglio per fresa T4490.S009

Cutting data T4490.S009 milling cutter

Schnittparameter für T4490.S009 Fräser

Mat.	HB <sup>(a)</sup> N/mm <sup>2(b)</sup> HrC <sup>(c)</sup>	Kc <sup>(1)</sup>	Finishing 0,1xD		Medium 0,2xD		Roughing 0,7xD		Slotting 1xD		Vc			
			Ap	Fz	Ap	Fz	Ap	Fz	Ap	Fz	KH108	KH78	KH58	K15
P1	125(a) / 420(b)	1350	3,0-5,0	0,43-0,54	3,0-4,0	0,40-0,50	2,5-3,0	0,22-0,24	1,5-2,5	0,18-0,20	250-350		220-270	
P2	190(a) / 650(b)	1500		0,40-0,51		0,37-0,47		0,18-0,20		0,15-0,17	250-350		220-270	
P3	250(a) / 850(b)	1675		0,40-0,51		0,37-0,47		0,18-0,20		0,15-0,17	150-200		130-180	
P4	220(a) / 750(b)	1700		0,32-0,42		0,29-0,37		0,14-0,16		0,12-0,14	150-200		130-180	
P5	300(a) / 1000(b)	1900		0,27-0,35		0,23-0,29		0,14-0,16		0,12-0,14	120-170		110-150	
P6	200(a) / 600(b)	1775		0,40-0,51		0,37-0,47		0,18-0,20		0,15-0,17	150-200		130-180	
P7	275(a) / 930(b)	1675		0,27-0,35		0,23-0,29		0,14-0,16		0,12-0,14	140-190		120-160	
P8	300(a) / 1000(b)	1725		0,27-0,35		0,23-0,29		0,14-0,16		0,12-0,14	120-170		110-150	
P9	350(a) / 1200(b)	1800		0,21-0,28		0,18-0,23		0,11-0,13		0,10-0,12	120-170		110-150	
P10	200(a) / 680(b)	2450		0,27-0,35		0,23-0,29		0,14-0,16		0,12-0,14	100-150		90-140	
P11	325(a) / 1100(b)	2500		0,21-0,28		0,18-0,23		0,11-0,13		0,10-0,12	80-120		70-110	
M12	200(a) / 680(b)	1875	3,0-5,0	0,23-0,26	3,0-4,0	0,21-0,24	2,5-3,0	0,18-0,20	1,5-2,5	0,15-0,17			170-250	
M13	240(a) / 820(b)	1875		0,18-0,21		0,17-0,20		0,14-0,16		0,10-0,12		160-200		
M14	180(a) / 600(b)	2150		0,18-0,21		0,17-0,20		0,14-0,16		0,10-0,12		70-140		
K15	180(a)	1150	3,0-5,0	0,27-0,33	3,0-4,0	0,25-0,30	2,5-3,0	0,21-0,24	1,5-2,5	0,18-0,20	200-300			
K16	260(a)	1350		0,24-0,27		0,22-0,25		0,18-0,20		0,15-0,17	200-250			
K17	160(a)	1225		0,27-0,33		0,25-0,30		0,21-0,24		0,18-0,20	200-300			
K18	250(a)	1350		0,24-0,27		0,22-0,25		0,18-0,20		0,15-0,17	150-200			
N21	60(a)	700	3,0-5,0	0,31-0,36	3,0-4,0	0,26-0,30	2,5-3,0	0,22-0,24	1,5-2,5	0,18-0,20	600-1000			400-800
N22	100(a)	800		0,31-0,36		0,26-0,30		0,22-0,24		0,18-0,20	500-600			350-700
N23	75(a)	700		0,25-0,30		0,21-0,25		0,18-0,20		0,15-0,17	400-500			300-400
N24	90(a)	700		0,21-0,25		0,18-0,21		0,15-0,17		0,12-0,14	300-400			250-300
N25	130(a)	750		0,21-0,25		0,18-0,21		0,15-0,17		0,12-0,14	300-400			250-300
N26	110(a)	700		0,31-0,36		0,26-0,30		0,22-0,24		0,18-0,20	600-1000			350-700
N27	90(a)	700		0,21-0,25		0,18-0,21		0,15-0,17		0,12-0,14	400-500			300-400
N28	100(a)	700		0,31-0,36		0,26-0,30		0,22-0,24		0,18-0,20	300-400			250-300

### Esempio di lavorazione

Application example / Anwendungsbeispiele

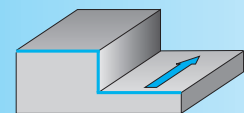

Materiale	Material	Material	C40
Trattamento termico	Heat treatment	Wärmebehandlung	No / No / Nein
Fresa	Milling cutter	Fräser	T4490 PM 040.S009 Z6 W
Inserti	Inserts	Wendeschnidplatte	SOKX 090308 PRD-M KH58
Refrigerante	Coolant	Kühlmittel	No / No / Nein
Velocità di taglio (V <sub>c</sub> )	Cutting speed (V <sub>c</sub> )	Schnittgeschwindigkeit (V <sub>c</sub> )	250 mt
Numero di giri (rpm)	Number of revolutions(rpm)	Drehzahl (rpm)	1.990 mm/min
Avanzamento tagliente (F <sub>z</sub> )	Tooth feed (F <sub>z</sub> )	Schneidkantenvorschub (F <sub>z</sub> )	0,2 mm
Avanzamento (F)	Feed rate (F)	Vorschub (F)	2.400 mm/min
Profondità di taglio radiale (A <sub>e</sub> )	Cutting width (A <sub>e</sub> )	Radiale Schnitttiefe	4 mm
Profondità di taglio assiale (A <sub>p</sub> )	Cutting depth (A <sub>p</sub> )	Axiale Schnitttiefe (A <sub>p</sub> )	6 mm
Volume truciolo (Q)	Chip volume (Q)	Zeitspanvolumen (Q)	58 cm <sup>3</sup> /min

**T4490 FRESA**  
**PER SPALLAMENTI RETTI**  
*Shoulder milling cutters*  
*Eckfräser 90 Grad*

**FRESE AD INSERTI**  
**INSERT MILLING CUTTERS**  
**WENDEPLATTEN-FRÄSWERKZEUGE**



## Inserto SO... 1304...

**Con fori di lubrorefrigerazione**

*With coolant holes*  
*mit Kühlmittelbohrungen*

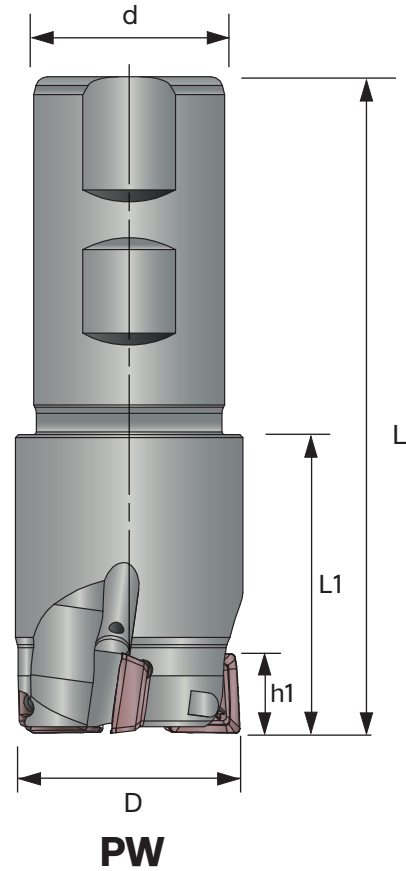
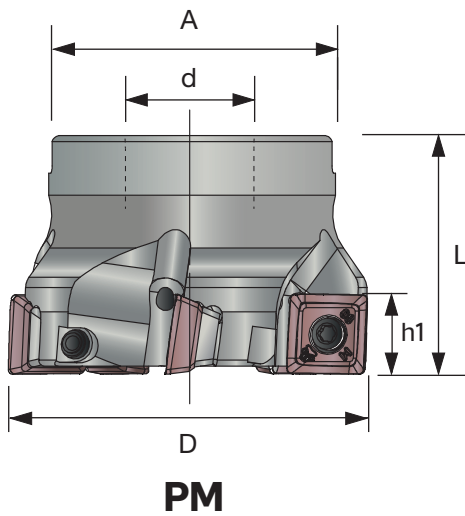

CODICE CODE	DIMENSIONI / DIMENSIONS / MAßE							INSERTO INSERT WSP					
	D	Z	d	L	L1	h1	A						
T4490PM 050.S013 Z4 W	50	4	22	40		13	44	SOKX 1304... SOEX 1304... XOKX 1304...	VT4490.13	CVT15P	S4490	B03550	CHEX035
T4490PM 050.S013 Z5 W	50	5	22	40		13	44				-	-	-
T4490PM 052.S013 Z4 W	52	4	22	40		13	44						
T4490PM 063.S013 Z5 W	63	5	22	40		13	48						
T4490PM 063.S013 Z6 W	63	6	22	40		13	48						
T4490PM 066.S013 Z5 W	66	5	22	40		13	48						
T4490PM 080.S013 Z6 W	80	6	27	50		13	58						
T4490PM 080.S013 Z7 W	80	7	27	50		13	58						
T4490PM 084.S013 Z6 W	84	6	27	50		13	58						
T4490PM 100.S013 Z7 W	100	7	32	50		13	78						
T4490PM 125.S013 Z8 W	125	8	40	63		13	78						
T4490PM 160.S013 Z10 W	160	10	40	63		13	101						
T4490PW 040.S013 Z3 W	40	3	32	45	50	13		VT4490.13	CVT15P	-	-	-	



**Per un corretto montaggio utilizzare il riferimento sull'inserto**

*Use the insert reference for a correct fitting up*

*Für die korrekte Montage der WSP achten Sie bitte auf die Bezugsmarkierung*



**T4490 FRESA**  
 PER SPALLAMENTI RETTI  
 Shoulder milling cutters  
 Eckfräser 90 Grad

**FRESE AD INSERTI**  
 INSERT MILLING CUTTERS  
 WENDEPLATTEN-FRÄSWERKZEUGE



## Inserti per fresa T4490.S013

Inserts for T4490.S013 milling cutter / WSP für T4490.S013 Fräser



CODICE CODE	DIMENSIONI DIMENSIONS / MAßE			P	M	K	N
	L	S	R				
SOKX 130408 PDR-F	13,5	4,76	0,8	KH108 KH58	KH78	KH108	
SOKX 130412 PDR-F	13,5	4,76	1,2	KH108 KH58	KH78	KH108	
SOKX 130404 PDR-M	13,5	4,76	0,4	TC2600	TC2600	KH118 TC2600	
SOKX 130408 PDR-M	13,5	4,76	0,8	KH108 KH58	KH78	KH108	
SOKX 130412 PDR-M	13,5	4,76	1,2	KH108 KH58	KH78	KH108	
SOKX 130416 PDR-M	13,5	4,76	1,6	KH108 KH58	KH78	KH108	
SOKX 130412 PDR-H	13,5	4,80	1,2	KH108 KH58	KH78	KH108	
SOKX 130416 PDR-H	13,5	4,80	1,6	KH108 KH58	KH78	KH108	
SOKX 130420 PDR-H	13,5	4,80	1,6				
SOEX 130408 PDR-LL	13,5	4,76	0,8				K15
XOKX 130408 PDR-W	13,5	4,76	0,8	KH108	KH108	KH108	



**RASCHIANTE**  
 Scraping  
 Breitschichtplatte



## Parametri di taglio per fresa T4490.S013

Cutting data T4490.S013 milling cutter

Schnittparameter für T4490.S013 Fräser

Mat.	HB <sup>(a)</sup> N/mm <sup>2(b)</sup> HrC <sup>(c)</sup>	Kc <sup>(1)</sup>	Finishing 0,1xD		Medium 0,2xD		Roughing 0,7xD		Slotting 1xD		Vc		
			Ap	Fz	Ap	Fz	Ap	Fz	Ap	Fz	KH108	KH78	KH58
P1	125(a) / 420(b)	1350	3,0-5,0	0,43-0,54	3,0-4,0	0,40-0,50	2,5-3,0	0,22-0,24	1,5-2,5	0,18-0,20	250-350		220-270
P2	190(a) / 650(b)	1500		0,40-0,51		0,37-0,47		0,18-0,20		0,15-0,17			
P3	250(a) / 850(b)	1675		0,40-0,51		0,37-0,47		0,18-0,20		0,15-0,17			
P4	220(a) / 750(b)	1700		0,32-0,42		0,29-0,37		0,14-0,16		0,12-0,14			
P5	300(a) / 1000(b)	1900		0,27-0,35		0,23-0,29		0,14-0,16		0,12-0,14			
P6	200(a) / 600(b)	1775		0,40-0,51		0,37-0,47		0,18-0,20		0,15-0,17			
P7	275(a) / 930(b)	1675		0,27-0,35		0,23-0,29		0,14-0,16		0,12-0,14			
P8	300(a) / 1000(b)	1725		0,27-0,35		0,23-0,29		0,14-0,16		0,12-0,14			
P9	350(a) / 1200(b)	1800		0,21-0,28		0,18-0,23		0,11-0,13		0,10-0,12			
P10	200(a) / 680(b)	2450		0,27-0,35		0,23-0,29		0,14-0,16		0,12-0,14			
P11	325(a) / 1100(b)	2500		0,21-0,28		0,18-0,23		0,11-0,13		0,10-0,12			
M12	200(a) / 680(b)	1875	3,0-5,0	0,23-0,26	3,0-4,0	0,21-0,24	2,5-3,0	0,18-0,20	1,5-2,5	0,15-0,17		170-250	
M13	240(a) / 820(b)	1875		0,18-0,21		0,17-0,20		0,14-0,16		0,10-0,12			
M14	180(a) / 600(b)	2150		0,18-0,21		0,17-0,20		0,14-0,16		0,10-0,12			
K15	180(a)	1150	3,0-5,0	0,27-0,33	3,0-4,0	0,25-0,30	2,5-3,0	0,21-0,24	1,5-2,5	0,18-0,20	200-300		
K16	260(a)	1350		0,24-0,27		0,22-0,25		0,18-0,20		0,15-0,17			
K17	160(a)	1225		0,27-0,33		0,25-0,30		0,21-0,24		0,18-0,20			
K18	250(a)	1350		0,24-0,27		0,22-0,25		0,18-0,20		0,15-0,17			
N21	60(a)	700	10,00	0,31-0,36	10,00	0,26-0,30	10,00	0,22-0,24	5,00-7,00	0,18-0,20	600-1000		
N22	100(a)	800		0,31-0,36		0,26-0,30		0,22-0,24		0,18-0,20			
N23	75(a)	700		0,25-0,30		0,21-0,25		0,18-0,20		0,15-0,17			
N24	90(a)	700		0,21-0,25		0,18-0,21		0,15-0,17		0,12-0,14			
N25	130(a)	750		0,21-0,25		0,18-0,21		0,15-0,17		0,12-0,14			
N26	110(a)	700		0,31-0,36		0,26-0,30		0,22-0,24		0,18-0,20			
N27	90(a)	700		0,21-0,25		0,18-0,21		0,15-0,17		0,12-0,14			
N28	100(a)	700		0,31-0,36		0,26-0,30		0,22-0,24		0,18-0,20			

### Esempio di lavorazione

Application example / Anwendungsbeispiele

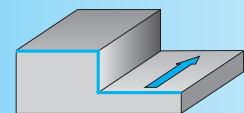

Materiale	Material	Material	C45
Trattamento termico	Heat treatment	Wärmebehandlung	Bonificato / Tempered steel / vergütet
Fresa	Milling cutter	Fräser	T4490 PM 050.S013 Z4 W
Inserti	Inserts	Wendeschnidplatte	SOKX 130413 PDR-M KH58
Refrigerante	Coolant	Kühlmittel	SI / Yes / Ja
Velocità di taglio (V <sub>c</sub> )	Cutting speed (V <sub>c</sub> )	Schnittgeschwindigkeit (V <sub>c</sub> )	300 m/min
Numero di giri (rpm)	Number of revolutions(rpm)	Drehzahl (rpm)	1900 rpm
Avanzamento tagliente (F <sub>z</sub> )	Tooth feed (F <sub>z</sub> )	Schneidkantenvorschub (F <sub>z</sub> )	0,47 mm
Avanzamento (F)	Feed rate (F)	Vorschub (F)	525 mm/min
Profondità di taglio radiale (A <sub>e</sub> )	Cutting width (A <sub>e</sub> )	Radiale Schnitttiefe	10 mm
Profondità di taglio assiale (A <sub>p</sub> )	Cutting depth (A <sub>p</sub> )	Axiale Schnitttiefe (A <sub>p</sub> )	8 mm
Volume truciolo (Q)	Chip volume (Q)	Zeitspanvolumen (Q)	288 cm <sup>3</sup> /min



# T4490



**BFT BURZONI S.r.l.**

*Sede Legale ed Amministrativa  
Legal and administrative headquarters  
Rechtlicher und administrativer Hauptsitz*

Via 1° Maggio 81-83

Località I Casoni

29027 Podenzano (PC) ITALY

tel. +39 0523.52.42.34 - fax +39 0523.55.99.41

[info@bftburzoni.com](mailto:info@bftburzoni.com) - [www.bftburzoni.com](http://www.bftburzoni.com)

